

SOUTHLAKE CORP

FILTER TRAY DE-PALLETISER & UNLOADER COMBINATION

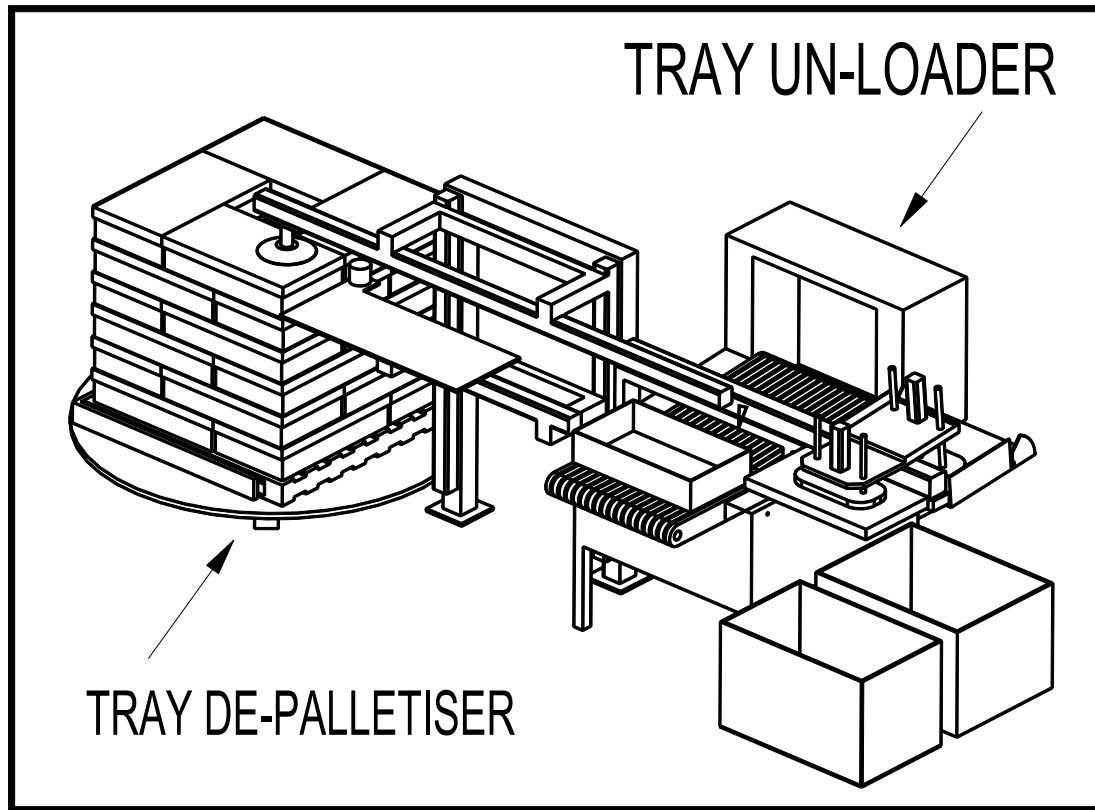

The TDP-1 & FTU-1 modules have been designed to be used as “stand alone” modules, or linked in the automatic mode. In the linked mode they give the unique capability to Cigarette & Filter manufacturers to automatically process filters supplied in cardboard trays on a pallet, directly into the plug feeders or filter tipping M/C with no manual intervention. The trays are automatically removed from the pallet and placed on the Tray Un-loader where the lid is removed and deposited in a bin. The filters are then extracted from the tray and discharged into a mass flow conveyor system (Ticon) linked to the plug feeders or filter tipping M/C, whilst the empty tray is discharged into the second bin.

Main Features

- TDP-1 Tray De-Palletiser – Fully automatic extraction of cardboard trays with tray base support.
- FTU-1 Tray Un-Loader – Fully automatic with lid removal & disposal; Fully controlled discharge of filters; Automatic empty tray disposal .
- Various mass flow Hopper & conveyor discharge systems (Ticon) available to suit host M/C's
- Linked modules available in several configurations (handed).
- Quick & easy size changing for filter lengths.
- Output speeds up to 6,000 rods/min.