

# ***SOUTHLAKE CORP***

---

## **FHG2SYSM – FILTER HOT MELT GRAVITY APPLICATION**

**For**

**KDF2 FILTER MAKING MACHINES**

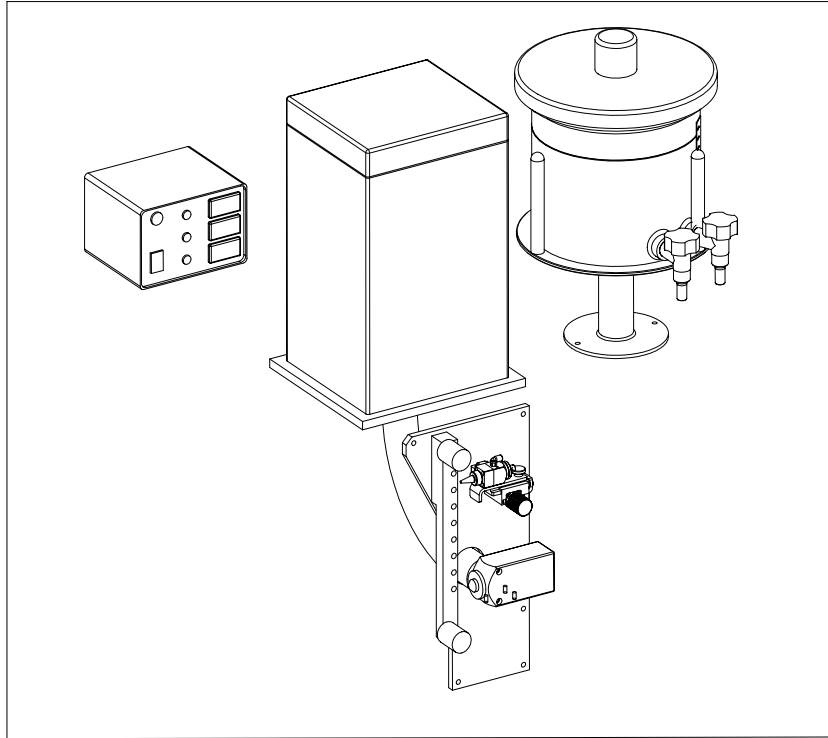

The FHG2SYSM Filter Hot Melt Gravity Application System is designed for specific use on the Hauni KDF2 Filter making machine this application system is based upon the well proven gravity principle for applying both the seam hot melt line & the PVA tow retention line. The gravity applicator applies a thin flat film of hot melt adhesive on to the surface of the paper; this type of application virtually eliminates “adhesive bleed through” even with porous paper.

### **Main Features**

- No moving parts when machine is running.
- Reduction in Adhesive consumption when compared with a pump system.
- No pressure applied to the adhesive during application, eliminating “bleed through”
- Temperature controlled graded zones to eliminate adhesive degradation.
- New Polyethylene PVA tanks.
- Full X & Y adjustment to both applicators.
- Flow proportional with machine speed.